



**LENJAX**

WHERE ENGINEERING & EFFICIENCY MEET COMFORT

# PVS POLYVINYL DUCT

For Underground Burial or Under Slab Applications. Can Be Fabricated For Both Positive And Negative Pressure

Our supplier for what you and I would call "PVC Coated Metal" is Wheeling Service & Supply. They call the material PVS once the material is applied to the metal. They were just bought out by Vorteq Coil. We imagine they will



MID-ATLANTIC CHAPTER

Representing Sheet Metal and Air Conditioning Contractors from Maryland, Virginia, Washington, D.C. and Eastern West Virginia



SHEET METAL WORKERS LOCAL 100

DC Duct & Sheet Metal LLC • **301-864-3828** • [www.dcduct.com](http://www.dcduct.com)  
**202-575-0189**

*Your Local Spiral Duct & Oval Duct Connection*

Office: 2520 Pennsylvania Avenue, SE · Washington, DC 20020

Shop: 3711 Wells Avenue · Mount Rainier, MD 20712



PVS DUCTWORK WITH COILS & FLAT SHEETS BY WHEELING SERVICE & SUPPLY / VORTEQ COILS

## PVS GORE LOCKED ELBOWS

### 90 Degree Gore Locked Elbows

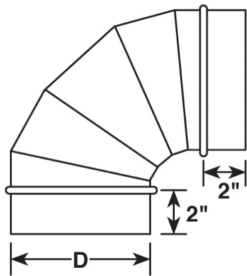

### 45 Degree Gore Locked Elbows

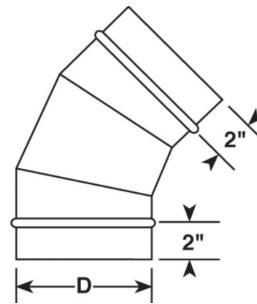

Gore Locked Elbows work well for medium pressure applications. They offer an alternative to riveted elbows. Available from 6" through 60" diameters. Fabricated as heavy as 16 gauge.

DC Duct & Sheet Metal LLC • **301-864-3828** • [www.dcduct.com](http://www.dcduct.com)  
**202-575-0189**

*Your Local Spiral Duct & Oval Duct Connection*



PVS DUCTWORK WITH COILS & FLAT SHEETS BY WHEELING SERVICE & SUPPLY / VORTEQ COILS

PVS FITTINGS

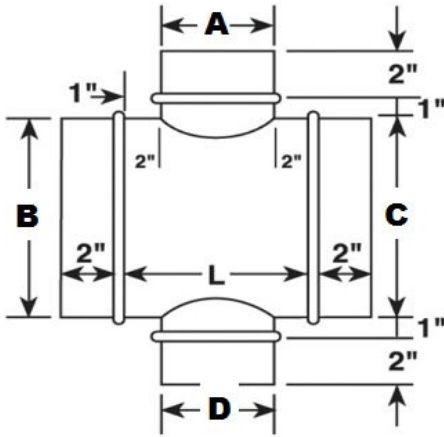

Cross with Reducer

Cross

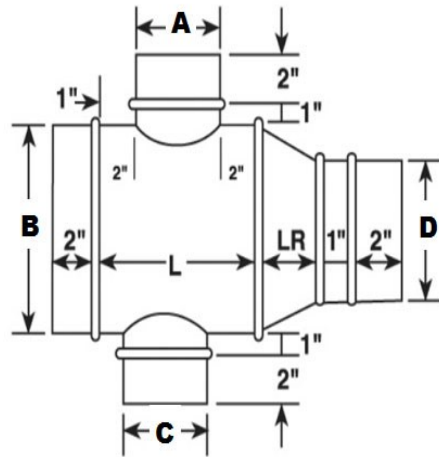
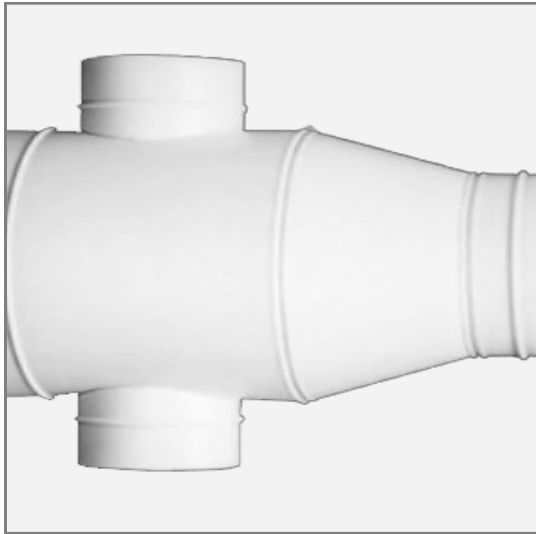

DC Duct & Sheet Metal LLC • **301-864-3828** • [www.dcd duct.com](http://www.dcd duct.com)  
**202-575-0189**

*Your Local Spiral Duct & Oval Duct Connection*



PVS DUCTWORK WITH COILS & FLAT SHEETS BY WHEELING SERVICE & SUPPLY / VORTEQ COILS

PVS FITTINGS

90° Tee

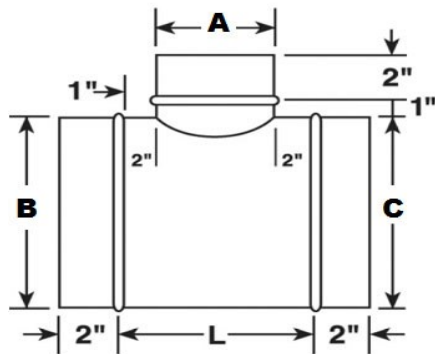

Tee with Reducer

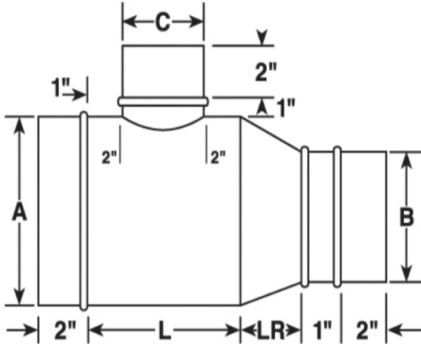
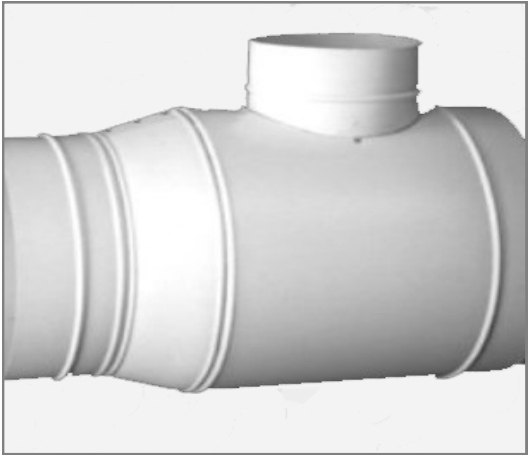
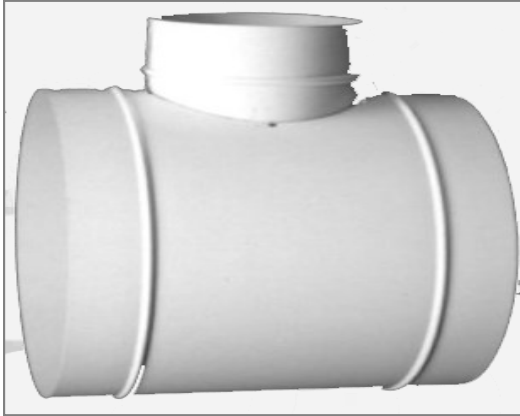

DC Duct & Sheet Metal LLC • **301-864-3828** • [www.dcduct.com](http://www.dcduct.com)  
**202-575-0189**

*Your Local Spiral Duct & Oval Duct Connection*



PVC DUCT

PVS DUCTWORK WITH COILS & FLAT SHEETS BY WHEELING SERVICE & SUPPLY / VORTEQ COILS

PVS FITTINGS

Lateral Cross

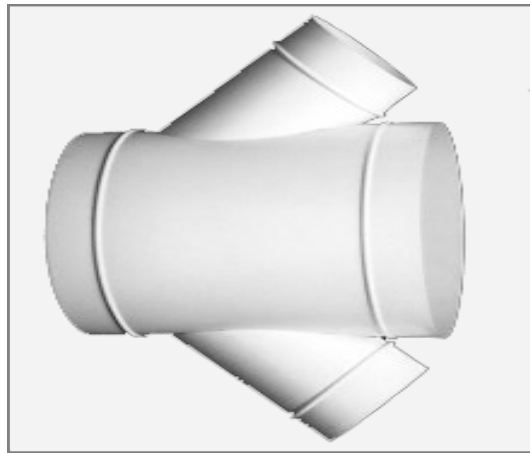
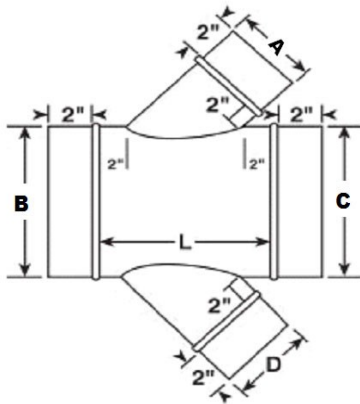

Lateral Cross with Reducer

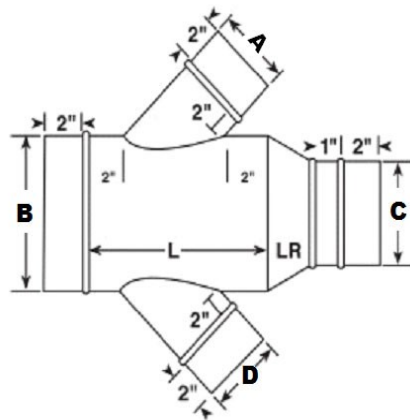
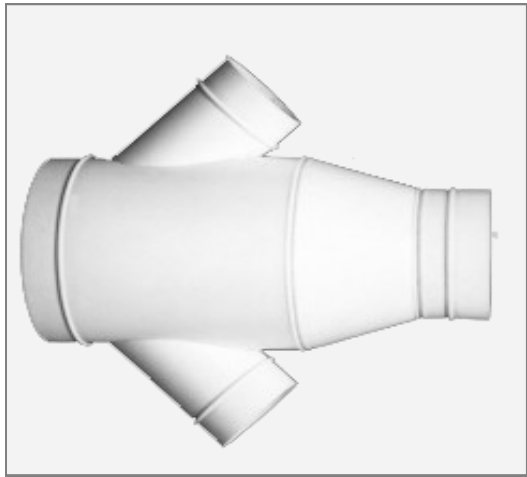

DC Duct & Sheet Metal LLC • **301-864-3828** • [www.dcdirect.com](http://www.dcdirect.com)  
**202-575-0189**

*Your Local Spiral Duct & Oval Duct Connection*



PVS DUCTWORK WITH COILS & FLAT SHEETS BY WHEELING SERVICE & SUPPLY / VORTEQ COILS

PVS FITTINGS

Lateral

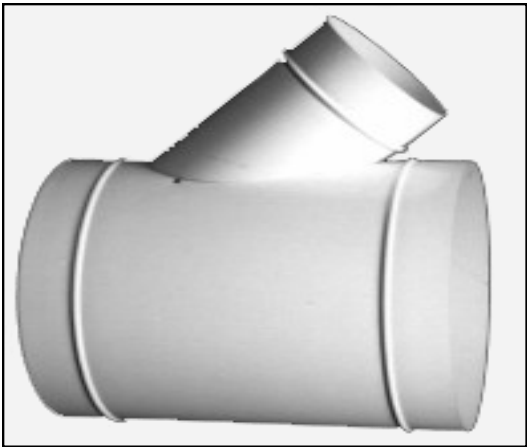
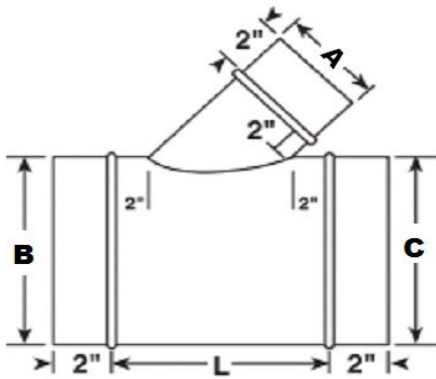

Lateral with Reducer

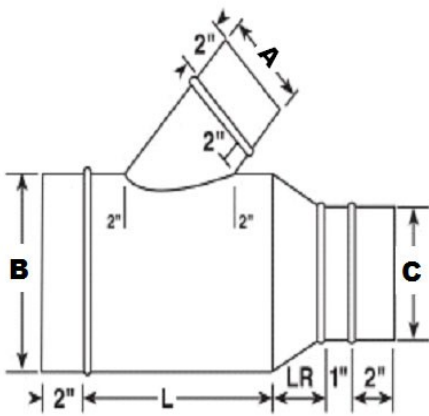
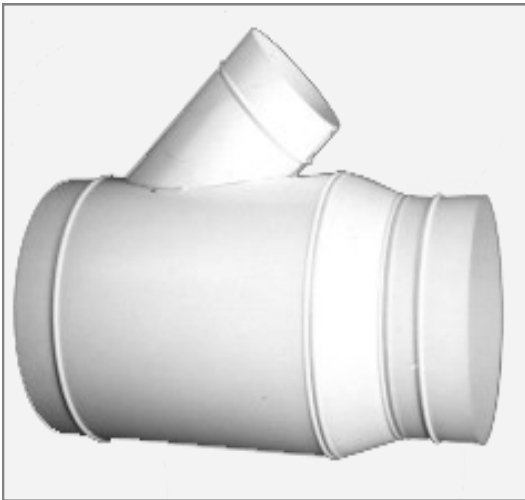

DC Duct & Sheet Metal LLC • **301-864-3828** • [www.dcdct.com](http://www.dcdct.com)  
**202-575-0189**

*Your Local Spiral Duct & Oval Duct Connection*



PVS DUCTWORK WITH COILS & FLAT SHEETS BY WHEELING SERVICE & SUPPLY / VORTEQ COILS

Size Reduction	LR
1	6
2	8.5
3	11
4	13.5
5	16
6	18.5
7	21
8	23.5
9	26
10	28.5
11	31
12	33.5
14	38.5
16	43.5
18	48.5
20	53.5

**PVS FITTINGS**

**Lateral**

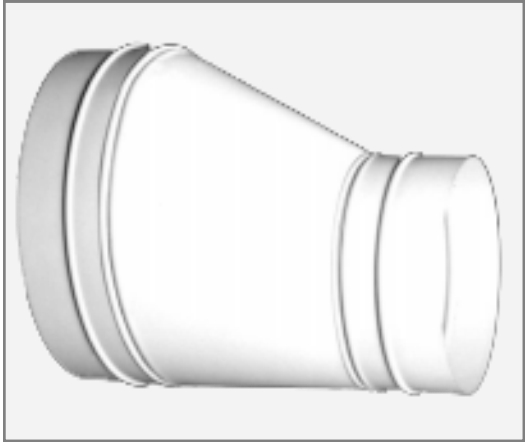
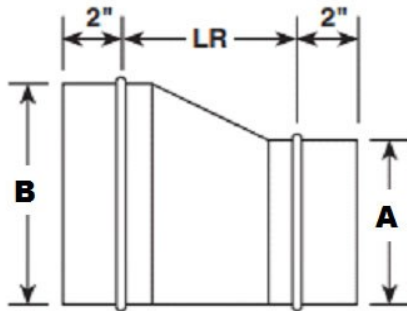

**Lateral with Reducer**

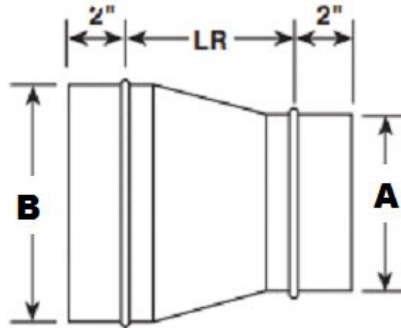
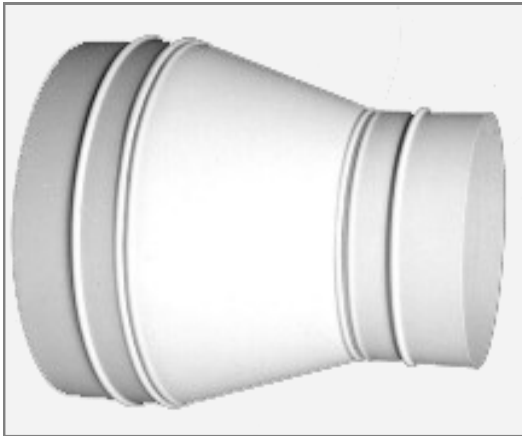

Size Reduction	LR
1	6.5
2 & 3	7.5
4	9.5
5	10.5
6	11.5
7	13.5
8	14.5
9	16.5
10	17.5
11	18.5
12	20.5
13	21.5
14	22.5
15 & 16	25.5
17 & 18	28.5
19	29.5
20	31.5
21	32.5
22	33.5

DC Duct & Sheet Metal LLC • **301-864-3828** • [www.dcd duct.com](http://www.dcd duct.com)  
**202-575-0189**

*Your Local Spiral Duct & Oval Duct Connection*



PVS DUCTWORK WITH COILS & FLAT SHEETS BY WHEELING SERVICE & SUPPLY / VORTEQ COILS

PVS FITTINGS

LR Value for Tees and Crosses			
Size Reduction	LR	Size Reduction	LR
1	4.75	12	20.25
2	5.75	13	21.25
3	5.75	14	22.25
4	7.75	15	25.25
5	8.75	16	25.25
6	9.75	17	28.25
7	13.25	18	28.25
8	14.25	19	29.25
9	16.25	20	31.25
10	17.25	21	32.25
11	18.25	22	33.25

- Add 1.5" to LR value for Diameters over 18"

DC Duct & Sheet Metal LLC • **301-864-3828** • [www.dcd duct.com](http://www.dcd duct.com)  
**202-575-0189**

*Your Local Spiral Duct & Oval Duct Connection*





PVS DUCTWORK WITH COILS & FLAT SHEETS BY WHEELING SERVICE & SUPPLY / VORTEQ COILS

**PVS FITTINGS**

A	Cone Diameter
4"	5"
5"	6"
6"	8"
7"	9"
8"	10"
9"	11"
10"	12"
12"	14"
14"	16"
16"	18"
18"	20"

**Conical Tap with Takeoff Collar**

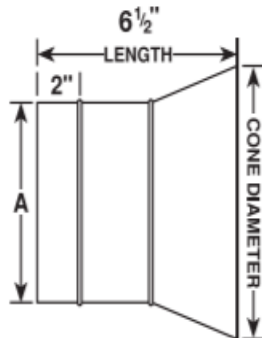

**Conical Takeoff Collar with Damper**

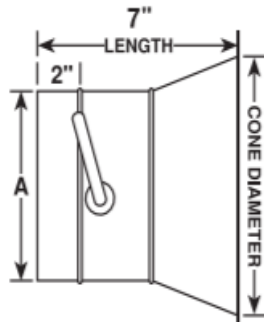

A	Cone Diameter
4"	5"
5"	6"
6"	8"
7"	9"
8"	10"
9"	11"
10"	12"
12"	14"
14"	16"
16"	18"
18"	20"

DC Duct & Sheet Metal LLC • **301-864-3828** • [www.dcdirect.com](http://www.dcdirect.com)  
**202-575-0189**

*Your Local Spiral Duct & Oval Duct Connection*



PVS DUCTWORK WITH COILS & FLAT SHEETS BY WHEELING SERVICE & SUPPLY / VORTEQ COILS

## PVS FITTINGS

### Round Tap on Flat

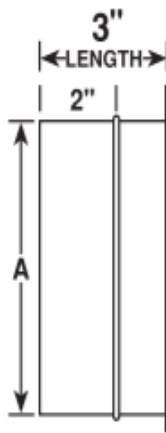

### Round Tap on Flat with Damper

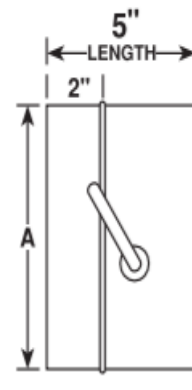

DC Duct & Sheet Metal LLC • **301-864-3828** • [www.dcd duct.com](http://www.dcd duct.com)  
**202-575-0189**

*Your Local Spiral Duct & Oval Duct Connection*



PVS DUCTWORK WITH COILS & FLAT SHEETS BY WHEELING SERVICE & SUPPLY / VORTEQ COILS

PVS FITTINGS

90° Rolled Saddle

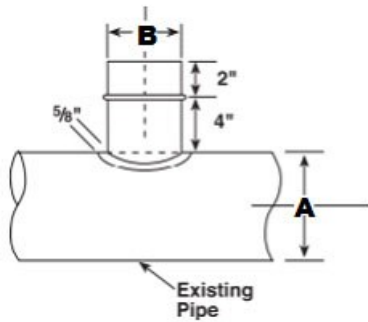

45° Rolled Saddle

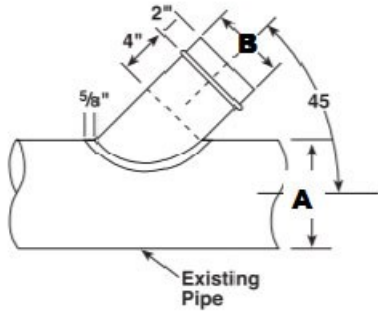
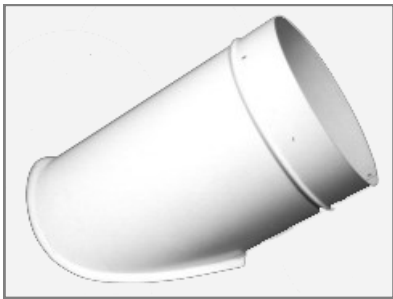

DC Duct & Sheet Metal LLC • **301-864-3828** • [www.dcdirect.com](http://www.dcdirect.com)  
**202-575-0189**

*Your Local Spiral Duct & Oval Duct Connection*



PVS DUCTWORK WITH COILS & FLAT SHEETS BY WHEELING SERVICE & SUPPLY / VORTEQ COILS

PVS FITTINGS

90° Saddle Tap with Collar

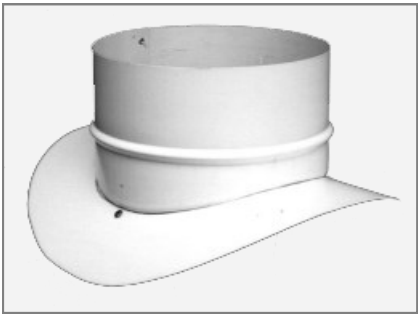
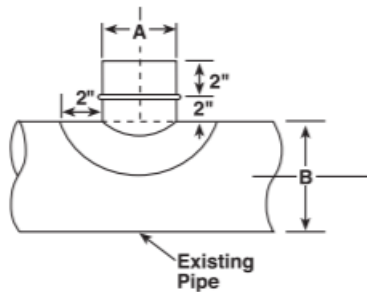

45° Saddle Tap with Collar

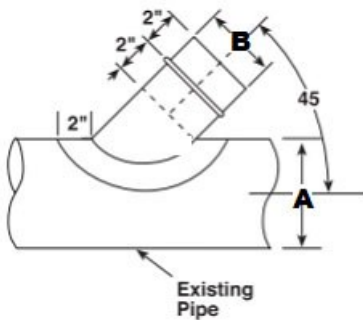
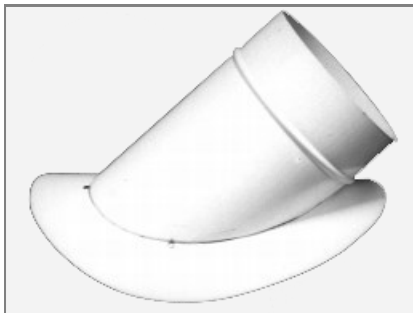

DC Duct & Sheet Metal LLC • **301-864-3828** • [www.dcduct.com](http://www.dcduct.com)  
**202-575-0189**

*Your Local Spiral Duct & Oval Duct Connection*



PVS DUCTWORK WITH COILS & FLAT SHEETS BY WHEELING SERVICE & SUPPLY / VORTEQ COILS

PVS FITTINGS

Notched Start Collars

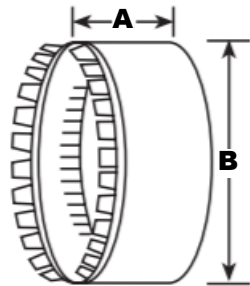

End Cap

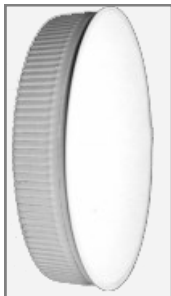

DC Duct & Sheet Metal LLC • **301-864-3828** • [www.dcd duct.com](http://www.dcd duct.com)  
**202-575-0189**

*Your Local Spiral Duct & Oval Duct Connection*



PVS DUCTWORK WITH COILS & FLAT SHEETS BY WHEELING SERVICE & SUPPLY / VORTEQ COILS

## PVS FITTINGS

### Coupling

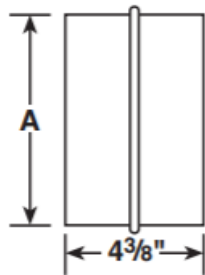

## PVS ACCESSORIES

### PVS Touch-Up

A special formulation of poly-vinyl. Air drying method for quick scratch repair.

### PVS Tape

Our PVS Tape is strong, permanent, and ideal for underground use. Works well in conjunction with sheet metal screws to complete any installation. Adhesive quality is sufficient for either hot and cold weather.

DC Duct & Sheet Metal LLC • **301-864-3828** • [www.dcduct.com](http://www.dcduct.com)  
**202-575-0189**

*Your Local Spiral Duct & Oval Duct Connection*



PVS DUCTWORK WITH COILS & FLAT SHEETS BY WHEELING SERVICE & SUPPLY / VORTEQ COILS

PVS FITTINGS

90° Register Tap

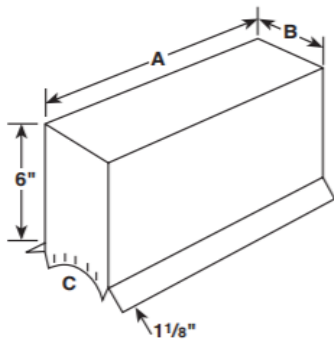

Register Boot

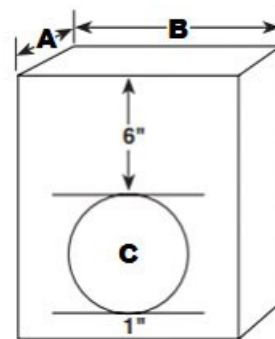
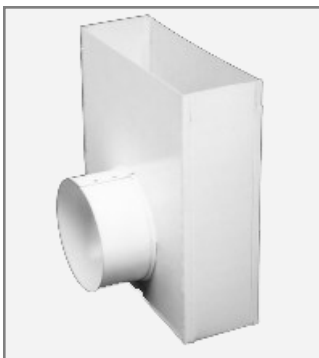

DC Duct & Sheet Metal LLC • **301-864-3828** • [www.dcd duct.com](http://www.dcd duct.com)  
**202-575-0189**

*Your Local Spiral Duct & Oval Duct Connection*



## P.V.S. DIVISION

Thank you for your interest in our P.V.S. steel for underground and corrosive fume ductwork. We have been supplying the trades with this coated steel since 1968, when we developed it. Our P.V.S. steel is available with either a 4x1 or 4x4 coating as standard. Special thicknesses are available on request. As you can see from the diagram below, the coating is heat fused to the primer, which is also heat fused to the galvanized metal after cleaning and treating. We have been doing the coating in house since 1971. This allows us to carefully control the quality of our product by monitoring all aspects of the process, as well as enabling us to supply material that can be made into duct that can carry the U/L label. 48" and 60" wide coils and sheets 60" and narrower are also available.



## The P.V.S. Coating Process

1. Begins with hot dipped galvanized steel, G-80 or better that is cleaned and treated for coating.
2. Then a special primer is baked onto both sides.
3. Finally, a special 4 mil. Polyvinyl chloride coating is baked onto either one side (4x1) or both sides (4x4).

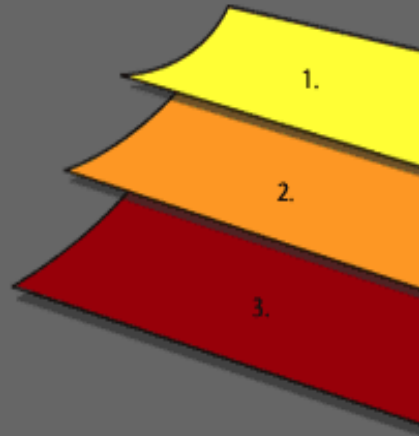

Our coatings are formulated to prevent mold growth and to meet U/L spec. 181 for flame spread and smoke developed.

## P.V.S. Literature

- [Anatomy of Installing Air Duct](#)
- [P.V.S. Data Sheet](#)
- [Mechanical Engineer Specifications](#)

## Material Safety Data Sheet

- [Antimicrobial Coated Steel GHS SDS](#)
- [Prepainted Aluminum GHS SDS](#)
- [Prepainted Cold Rolled Steel GHS SDS](#)
- [PVS Galvanized Steel GHS SDS](#)
- [SDS PVS Duct Sealer](#)
- [SDS PVS TouchUp Paint Brush](#)
- [SDS PVS TouchUp Spray](#)

If you have pricing questions contact us at 1-815-338-6410

or use our convenient [ONLINE QUOTE](#)



# P.V.S.<sup>®</sup>

## Mechanical Engineer Specifications

For Underground Air Duct and Ducting Corrosive Fumes



### The Original Plastic Coated Steel

Plastic heat-fused to galvanized steel — a proven product since 1967.

Suitable for underground burial without concrete encasement under most conditions.

Meets U/L Spec 181 Class 1

See Building Inspector Notice on back page.

Fire marshals throughout the country and  
hundreds of cities and counties have approved  
P.V.S. in their building codes.

Specify P.V.S. for your underground and  
Corrosive fume duct requirements.

P.V.S. is available nationwide.

Meets all requirements of U/L Spec 181 including mold growth.

Look for the Trademark.

Only P.V.S. carries the registered trademark for your protection  
don't be fooled by brand "X". P.V.S. is wheeling Service & Supply's

## Specifications for Underground Ducts

**1** All underground duct is designed as 4x1 P.V.S. coating. Duct to be made with 4 mil to outside and .1 mil epoxy backcoat is inside and can be visually seen by trademark printing.

**2** The following diameters are to be manufactured in accordance to the following chart.

3"0 – 8"0	26 Gauge P.V.S.
9"0 – 16"0	24 Gauge P.V.S.
17"0 – 24"0	22 Gauge P.V.S.
25"0 – 32"0	20 Gauge P.V.S.
33"0 – 80"0	18 Gauge P.V.S.

**3** When duct is 14" or more in diameter, it should be corrugated with external corrugation.



Longitudinal section of a corrugated tube wall

**4** Load Specifications

#1 Standard	4"0 - 8"0	400 lbs. /Linear Ft.	<i>See trenching and backfill, page 2 of BP-120. Any duct work installed over 3 feet caution is to be taken on compacting around duct. On great depths, bridging or supports used internal or external are recommended.</i>
	10"0 - 12"0	800 lbs. /Linear Ft.	
#2 Corrugated	14"0 - 36"0	2000 lbs. /Linear Ft.*	

**5** All ducts should be constructed of P.V.S. material in accordance with manufacturer's specifications. See Anatomy of Installing P.V.S. Air Duct, form BP-120.

- (a) All pipe and fittings are to be constructed of P.V.S. material.
- (b) All duct sections should be joined by connectors using P.V.S. material.
- (c) All joints should be sealed with sealant and taped in order to insure an air-tight joint.
- (d) All ducts and fittings should be installed using a clean sand and pea gravel for backfilling.

**6** Scratched surfaces - If, through a field accident the P.V.S. coating is scratched so as to expose the bare metal, apply P.V.S. touch up paint to the injured surface. This can be prayed or brushed on. Apply liberally and allow time for drying. The damaged surface is then ready for service.

**7** P.V.S. is available in sheets or coils.

**8** P.V.S. temperature limits - Temperature limits for P.V.S. are normal for most industrial ducting needs. It is unaffected by cold down to  $-40^{\circ}$  F. and will withstand a constant heat of up to  $250^{\circ}$  F. with limited exposure to  $400^{\circ}$  F.

### P.V.S. Underground Duct Size, Gauge and Weight

Duct Diameter	Gauge	Weight Per Ft.	Duct Diameter	Gauge	Weight Per Ft.
4"	26	1.1	24"	22	12.0
6"	26	1.6	26"	20	13.5
8"	26	2.1	28"	20	15.0
10"	24	3.6	30"	20	21.9
12"	24	4.3	32"	20	23.4
14"	24	5.1	34"	18	24.8
16"	24	7.0	36"	18	26.2
18"	22	7.7	40"	18	29.3
20"	22	8.6	44"	18	32.0
22"	22	9.5	48"	18	35.0

*Diameter up to 80" 14 gauge*

### Specifications Ducting Corrosive Fumes

- 1 When specifying P.V.S. for fume exhaust systems, utmost attention must be given to the fact that the greatest exposure will be internal not external. In most cases, 4x1 coating will be sufficient. Reversed 4 mils of P.V.S. coating on the inside surface and .1 mil epoxy backcoat on the outside. This must be stated in specifications.
- 2 In certain instances where external as well as internal exposure is anticipated, specifications should be stated as 4x4 P.V.S. This insures protection on both sides of duct work.
- 3 P.V.S. is available in sheet stock with either 4x1 or 4x4 coating. Thus, hoods, vents, etc. can be fabricated with P.V.S. keeping the system as complete and uniform as possible. Hoods, vents and other fittings may be custom made on the job by contractors or ordered per specifications through P.V.S. manufacturers.
- 4 P.V.S. is ideal for hoods where exposure to radioactive isotopes is involved. There is no existing code - stainless steel is used only because of the ease of cleanup. But P.V.S. can be cleaned just as easily.
- 5 Sealant is applied to all exposed edges and rivets.
- 6 P.V.S. Acid, see 101-A.

## Building Inspector Notice

- 1 Our 4x1 material meets the flame spread and smoke developed requirements of U/L Specification 181, Class 1.
- 2 In order for our made air ducts to carry a **U/L label** for the U/L Specification Standard 181, the ducts must have *both of* these:
  - (a) component manufacturer identifying mark, and also
  - (b) U/L listing label.
- 3 Our imprinting on the .1 side of the duct identifies that the material is a U/L listed component, and the U/L label identifies the U/L file and *duct* manufacturer showing the *completed* duct is a U/L listed product. The U/L listing label is applied by the approved duct manufacturer.
- 4 If the duct manufacturer's U/L listing is not attached to the duct, it is **not** a U/L listed product.

### Mechanical Engineers Specifications for Underground Air Duct

#### Web Address for this document

[http://www.wheelingservice.com/capabilities/090413\\_WSS\\_Mech\\_Engineer\\_Specs.pdf](http://www.wheelingservice.com/capabilities/090413_WSS_Mech_Engineer_Specs.pdf)



**P.V.S.** MANUFACTURING DIVISION

*P.V.S. is an exclusive product of:*

**WHEELING SERVICE & SUPPLY, INC.**

P.O. Box 189 | Woodstock, Illinois 60098-0189

Telephone: (815) 338-6410 | Fax: (815) 338-4738

[www.wheelingservice.com](http://www.wheelingservice.com)

The Distributor for P.V.S. products in the area is:



**301-864-3828**

[www.dcdut.com](http://www.dcdut.com)

This copyrighted material has been reproduced for quality enhancement & distribution purposes only.  
DC Duct & Sheet Metal, LLC. has not changed or altered the copyrighted content in any manner.

The information contained herein is, to the best of our knowledge and belief, accurate. However, since the conditions of handling and use are beyond our control, we make no guarantee of results and assume no liability for damages incurred by following these suggestions. Nothing contained herein is to be construed as a recommendation for use in violation of applicable laws or regulations. P.V.S. is a registered trademark for Wheeling Service & Supply's brand of plastic-steel products. Registered trademarks issued by U.S. Patent Office, Numbers 840-476 and 868.989

# P.V.S.<sup>®</sup>

## Anatomy of Installing Air Duct

An Illustrated Worksheet of Procedures



*Featuring:*

Trenching and Backfill

Cutting in the Field

Scratched Surfaces

Connecting P.V.S. Fitting and Sections

Air Conditioning and Heating Systems

\* U/L Listed Air Duct Class 1

## Trenching and Backfill



After the excavation has been made, no special bedding need be used for P.V.S. ducting, as long as adequate drainage is provided to insure that the duct does not sit in water or moist locations. We recommend the duct be installed on a bed of sand and pea gravel. This can be shoveled in beneath the duct if major gaps appear. The material taken from the trench can be used to backfill, but care should be taken not to dump or push heavy loads directly on the duct. It can be crushed under thoughtless abuse. Spread the backfill material evenly around both sides of the duct—tamping in place is a recommended practice. Then only one pour of cement is needed to cover the duct and complete the slab floor.

No cement is needed to fill in around the duct, since the tamped fill holds the duct in place and the plastic coating prevents ground corrosion of the galvanized steel. This plastic coating also is resistant to most minerals or salts that may be in the backfill soil. P.V.S. duct will not “float” when backfilled to within 2” of the top of the duct. Concrete is then poured so that all “tie down” work is eliminated.

*When duct is 14” or more in diameter, it should be corrugated.*

## Cutting in the Field



To cut duct to size, mark line to be followed with a standard marking crayon. Then cut along guideline with a power driven hand saw or tin snips.

## Scatched Surfaces



If, through a field accident, the P.V.S. coating is scratched or scarred so as to expose the base metal, apply P.V.S. touch-up paint to the damaged surface. This can be sprayed or brushed on. Apply liberally and allow time for drying. The damaged surface is then ready for service — a new protective coating has been added on.

## Connecting P.V.S. Fitting and Sections

### Connecting P.V.S. Fittings with Sheet Metal Screws and P.V.S. Sealant

Section is joined with section by means of the P.V.S. sleeve, which is inserted into the ends of the sections being connected. The sleeve is attached to the duct by means of sheet metal screws spaced on approximately 6" centers around the circumference. Sealant is applied on the outside of the sleeve and inside the duct ends before inserting the sleeves. An additional coating of Sealant is applied over the joint and screws to assure an air tight connection. Tape is then applied to make the connection airtight.



### P.V.S. Fittings and P.V.S. Sleeves for P.V.S. Duct Sections

P.V.S. fittings and connectors are manufactured of the same material as the P.V.S. duct. The ends of both P.V.S. fittings and P.V.S. sleeves are crimped to allow easy insertion into the P.V.S. duct section.



### Connecting P.V.S. Sections with Duct Tape

Duct tape is recommended, as it is ideal for this usage. Wrap 2-3 laps of tape tightly around joints. It is recommended that the joints be covered with approved duct sealer as specified above.



## For Air Conditioning and Heating Systems — A Typical P.V.S. Duct Installation

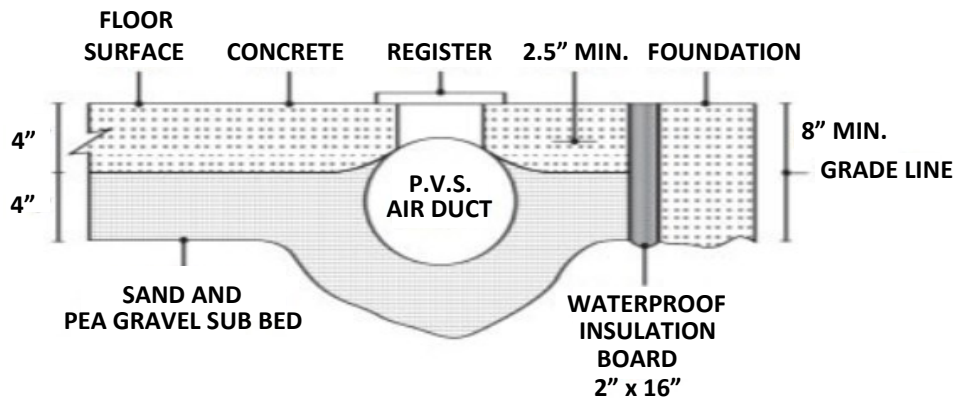
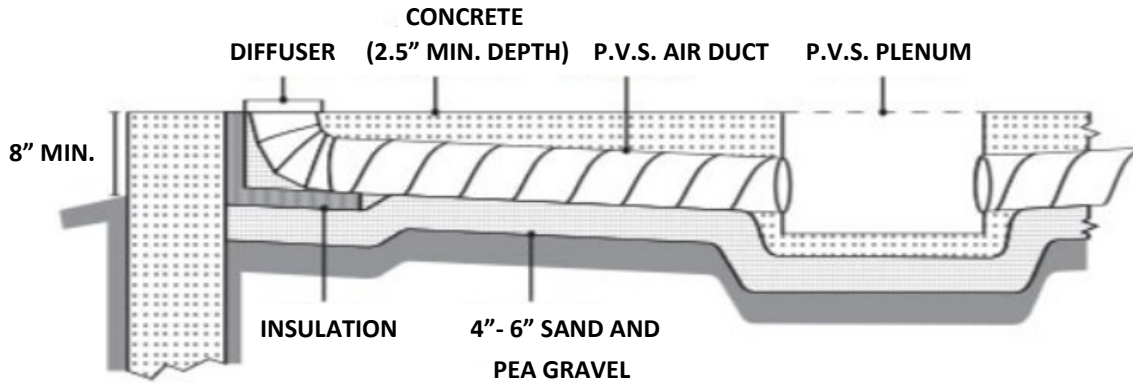

### Installation of PVS Air Duct

### Web Address for this document

[http://www.wheelingservice.com/capabilities/090413\\_WSS\\_Anatomy.pdf](http://www.wheelingservice.com/capabilities/090413_WSS_Anatomy.pdf)



**PVS** MANUFACTURING DIVISION

*P.V.S. is an exclusive product of:*

**WHEELING SERVICE & SUPPLY, INC.**

P.O. Box 189 | Woodstock, Illinois 60098-0189

Telephone: (815) 338-6410 | Fax: (815) 338-4738

[www.wheelingservice.com](http://www.wheelingservice.com)

The Distributor for P.V.S. products in the area is:



**301-864-3828**

[www.dcduct.com](http://www.dcduct.com)

This copyrighted material has been reproduced for quality enhancement & distribution purposes only.

DC Duct & Sheet Metal, LLC. has not changed or altered the copyrighted content in any manner.

The information contained herein is, to the best of our knowledge and belief, accurate. However, since the conditions of handling and use are beyond our control, we make no guarantee of results and assume no liability for damages incurred by following these suggestions. Nothing contained herein is to be construed as a recommendation for use in violation of applicable laws or regulations. P.V.S. is a registered trademark for Wheeling Service & Supply's brand of plastic-steel products. Registered trademarks issued by U.S. Patent Office, Numbers 840-476 and 868.989