



**DC DUCT &  
SHEET METAL, LLC**



**LENJAX**

WHERE ENGINEERING & EFFICIENCY MEET COMFORT

# SPIRAL DUCT & FITTINGS



MID-ATLANTIC CHAPTER

Representing Sheet Metal and Air Conditioning Contractors  
from Maryland, Virginia, Washington, D.C. and Eastern West Virginia



**SHEET METAL WORKERS LOCAL 100**

DC Duct & Sheet Metal LLC • **301-864-3828** • [www.dcdirect.com](http://www.dcdirect.com)  
**202-575-0189**

*Your Local Spiral Duct & Oval Duct Connection*

Office: 2520 Pennsylvania Avenue, SE · Washington, DC 20020

Shop: 3711 Wells Avenue · Mount Rainier, MD 20712

**Spiral Duct Material Options**

Our products are fabricated from a variety of materials. Not all of our products are available in all materials. All duct and fittings are manufactured to SMACNA - HVAC construction standards, metal and flexible, third edition, 2005.

Some will exceed this standard.

Materials	Description
Galvanized Steel	G90 or G60 hot dipped, lock forming quality galvanized steel meeting ASTM A924 and ASTM A653
Galvaneal Steel (Paintable)	Lock-forming quality paintable galvanized steel meeting ASTM 924 and ASTM A653
Stainless Steel	Type 304 in 2B finish (Ask about additional Types and Finishes) Type 316 in 2B finish (Ask about additional Types and Finishes)
Aluminum	3003 H14 aluminum alloy
PVC Coated	Polyvinyl Chloride Coated Steel with 4 mil x 1mil or 4 mil x 4 mil (inside / outside) coating

DC Duct & Sheet Metal LLC • **301-864-3828** • [www.deduct.com](http://www.deduct.com)  
**202-575-0189**

*Your Local Spiral Duct & Oval Duct Connection*

**Spiral Duct Capabilities**

SINGLEWALL CONSTRUCTION	AVAILABLE				GAUGES / THICKNESSES	
	MATERIALS	SIZES	SEAMS	LENGTHS	MIN.	MAX.
SPIRAL PIPE <sup>1</sup>	Galvanized (G60 & G90)		SPIRAL	1' - 20'	26 Ga.	14 Ga.
	Galvanized (Paintable)	4" - 72"+ Diam.		1' - 20'	24 Ga.	14 Ga.
	Stainless Steel (304 & 316)	4" - 72"+ Diam.		1' - 20'	24 Ga.	18 Ga.
	Aluminum (3003-H14)	4" - 72"+ Diam.		1' - 20'	0.024	0.071
	PVC Coated	4" - 72"+ Diam.		1' - 20'	24 Ga.	18 Ga.
LONGITUDINAL SEAM PIPE <sup>2</sup>	Galvanized (G60 & G90)	6" - 72"+ Diam.	SWB OR SWL	1' - 5'	20 Ga.	10 Ga.
	Galvanized (Paintable)	6" - 72"+ Diam.		1' - 5'	20 Ga.	10 Ga.
	Stainless Steel (304 & 316)	6" - 72"+ Diam.		1' - 4'	20 Ga.	10 Ga.
	Aluminum (3003-H14)	6" - 72"+ Diam.		1' - 4'	0.040	0.125
FITTINGS	Galvanized (G60 & G90)	4" - 72"+ Diam.			24 Ga.	10 Ga.
	Galvanized (Paintable)	4" - 72"+ Diam.	SPS, SWB OR SWL		24 Ga.	10 Ga.
	Stainless Steel (304 & 316)	4" - 72"+ Diam.	SPS, SWB OR SWL		24 Ga.	10 Ga.
	Aluminum (3003-H14)	4" - 72"+ Diam.	SPS, SWB OR SWL		0.032	0.125
	PVC Coated	4" - 72"+ Diam.	RV, SC		24 Ga.	18 Ga.

1. Spiral Pipe is available in lengths exceeding 20' by special order.
2. Minimum Gauges / Thicknesses vary by Seam Type. Not all Seams can be fabricated in all gauges.

DC Duct & Sheet Metal LLC • **301-864-3828** • [www.deduct.com](http://www.deduct.com)  
**202-575-0189**

*Your Local Spiral Duct & Oval Duct Connection*

**Double Wall Round Spiral Duct Insulated**

DOUBLEWALL (DW) & LINED CONSTRUCTION	OUTER SHELL MATERIALS (DW) AND LINED	INNER LINER MATERIALS (DW ONLY)	SEAMS	WALL THICKNESS	INSULATION / LINER
<b>SPIRAL PIPE<sup>1</sup> LONGITUDINAL SEAM PIPE AND FITTINGS</b>	Galvanized (G60 & G90)	1. Perforated Galvanized Steel with 3/32" holes on 3/16" centers.	Outer Shell Seams equal to Singlewall.	1", 2" & 3" (DW)	1", 2" & 3" X 0.75 PCF UNFACED
	Galvanized (Paintable)				
	Stainless Steel (304 & 316)	2. Solid Liner available in materials equal to OUTER SHELL	Inner liner Seams - Spiral for Pipe, Gorelocked for fittings.	1" & 1.5" (LINED)	JOHNS MANVILLE SPIRACOUSTIC AND SPIRACOUSTIC PLUS (LINED)
	Aluminum (3003-H14)				
	PVC Coated				

Oval duct is fabricated from spiral duct and the major and minor dimensions of the oval are limited to current spiral ovalizer machines on the market today.

(See next page)

DC Duct & Sheet Metal LLC • **301-864-3828** • [www.deduct.com](http://www.deduct.com)  
**202-575-0189**

*Your Local Spiral Duct & Oval Duct Connection*

**Spiral Duct Capabilities**

**ITEM**

**GALVANIZED**

Spiral Pipe 1  
Longseam Pipe 2,3  
Spot./Tack Welded  
Figs Fully Welded

26 Gauge		24 Gauge		22 Gauge		20 Gauge		18 Gauge		16 Gauge		14 Gauge		12 Gauge		10 Gauge	
Min. Dia.	Max. Dia.	Min. Dia.	Max. Dia.	Min. Dia.	Max. Dia.	Min. Dia.	Max. Dia.	Min. Dia.	Max. Dia.	Min. Dia.	Max. Dia.	Min. Dia.	Max. Dia.	Min. Dia.	Max. Dia.	Min. Dia.	Max. Dia.
4"	48"	4"	70"	4"	84"	4"	60"	4"	120"								
6"	14"	6"	26"	6"	36"	6"	50"	6"	60"								
4"	14"	4"	26"	4"	36"	4"	50"	4"	60"								
				4"	36"	4"	50"	4"	60"								

**STAINLESS STEEL**

Spiral Pipe 1  
Longseam Pipe 2,3  
Spot./Tack Welded Figs  
Fully Welded Fittings

26 Gauge		24 Gauge		22 Gauge		20 Gauge		18 Gauge		16 Gauge		14 Gauge		12 Gauge		10 Gauge	
Min. Dia.	Max. Dia.	Min. Dia.	Max. Dia.	Min. Dia.	Max. Dia.	Min. Dia.	Max. Dia.	Min. Dia.	Max. Dia.	Min. Dia.	Max. Dia.	Min. Dia.	Max. Dia.	Min. Dia.	Max. Dia.	Min. Dia.	Max. Dia.
		4"	70"	4"	84"	4"	60"	12"	120"								
<b>C</b>	<b>C</b>	6"	26"	6"	36"	6"	50"	6"	120"								
<b>C</b>	<b>C</b>	4"	26"	4"	36"	4"	50"	6"	120"								
				4"	36"	4"	50"	6"	120"								

**GALVANEAL**

Spiral Pipe 1  
Longseam Pipe  
Spot./Tack Welded Figs  
Fully Welded Fittings

26 Gauge		24 Gauge		22 Gauge		20 Gauge		18 Gauge		16 Gauge		14 Gauge		12 Gauge		10 Gauge	
Min. Dia.	Max. Dia.	Min. Dia.	Max. Dia.	Min. Dia.	Max. Dia.	Min. Dia.	Max. Dia.	Min. Dia.	Max. Dia.	Min. Dia.	Max. Dia.	Min. Dia.	Max. Dia.	Min. Dia.	Max. Dia.	Min. Dia.	Max. Dia.
		4"	70"	4"	84"	4"	60"	4"	120"								
		6"	26"	6"	36"	6"	50"	6"	60"								
		4"	26"	4"	36"	4"	50"	4"	60"								
				4"	36"	4"	50"	4"	60"								

DC Duct & Sheet Metal LLC • **301-864-3828** • [www.dcduct.com](http://www.dcduct.com)  
**202-575-0189**

*Your Local Spiral Duct & Oval Duct Connection*

**Spiral Duct Capabilities**

26 Gauge		24 Gauge		22 Gauge		20 Gauge		18 Gauge		16 Gauge		14 Gauge		12 Gauge		10 Gauge	
Min. Dia.	Max. Dia.	Min. Dia.	Max. Dia.	Min. Dia.	Max. Dia.	Min. Dia.	Max. Dia.	Min. Dia.	Max. Dia.	Min. Dia.	Max. Dia.	Min. Dia.	Max. Dia.	Min. Dia.	Max. Dia.	Min. Dia.	Max. Dia.
		4"	36"	4"	50"	4"	60"	4"	120"								
		6"	26"	6"	36"	6"	50"	6"	120"								
		4"	26"	4"	36"	4"	50"	4"	120"								

**PVC COATED**

Spiral Pipe <sup>1</sup>  
Longseam Pipe <sup>4,5</sup>  
Fittings <sup>4,5</sup>  
Fully Welded Fittings

**ALUMINUM**

Spiral Pipe <sup>1</sup>  
Longseam Pipe  
Spout /Tack Welded Figs  
Fully Welded Fittings

0.024/22 Ga.		0.032/20 Ga.		0.04/18 Ga.		0.05/16 Ga.		0.063/14 Ga.		0.071/13 Ga.		0.09/11 Ga.	
Min. Dia.	Max. Dia.	Min. Dia.	Max. Dia.	Min. Dia.	Max. Dia.	Min. Dia.	Max. Dia.	Min. Dia.	Max. Dia.	Min. Dia.	Max. Dia.	Min. Dia.	Max. Dia.
4"	48"	4"	70"	4"	84"								
6"	14"	6"	26"	6"	36"								
4"	14"	4"	26"	4"	36"								

**C** = Custom Product, please contact our Sales Department

**NOTES**







1. Spiral available in even and odd sizes through 30" and even sizes from 4" through 120"
2. Smaller diameters may be available as tubing
3. Larger sizes available on special order. Please call.
4. Longseam pipe and fittings fabricated from PVC material will be riveted, screwed or standing construction.
5. PVC Fittings may also be coated after fabrication

DC Duct & Sheet Metal LLC • **301-864-3828** • www.dcd duct.com  
**202-575-0189**

*Your Local Spiral Duct & Oval Duct Connection*

 <b>WEIGHT TABLE - GALVANIZED STEEL lbs/ft</b>									
TRIPLE RIB DUCT				TUBE DIA.  INCH	HELIX SMOOTH DUCT				
STRIP WIDTH					STRIP WIDTH				
6.024"	5.827"				5.394"			5.5"	
153 mm	148mm				137 mm			140mm	
STRIP THICKNESS					STRIP THICKNESS				
30Ga	28Ga	25Ga	24Ga		26Ga	24Ga	22Ga	20Ga	18Ga
0.015"	0.017"	0.019"	0.025"		0.019"	0.025"	0.031"	0.038"	0.050"
1.66	1.81	2.03	2.67	8	1.88	2.47	3.06	3.75	5.06
1.86	2.04	2.28	3.00	9	2.11	2.78	3.45	4.23	5.69
2.07	2.27	2.54	3.34	10	2.35	3.09	3.83	4.70	6.32
2.48	2.72	3.05	4.00	12	2.82	3.71	4.60	5.64	7.58
2.89	3.17	3.55	4.67	14	3.28	4.32	5.36	6.57	8.85
3.31	3.62	4.06	5.34	16	3.75	4.94	6.12	7.51	10.11
3.72	4.08	4.56	6.00	18	4.22	5.56	6.89	8.45	11.38
4.14	4.54	5.07	6.68	20	4.70	6.18	7.66	9.40	12.64
4.56	5.00	5.58	7.35	22	6.17	6.80	8.43	10.34	13.90
4.96	5.44	6.08	8.00	24	6.63	7.41	9.19	11.26	15.17
5.38	5.90	6.59	8.67	26	6.10	8.03	9.96	12.21	16.43
5.78	6.34	7.09	9.33	28	6.57	8.64	10.71	13.13	17.70
6.20	6.80	7.60	10.00	30	7.04	9.26	11.48	14.08	18.96
6.62	7.26	8.11	10.67	32	7.51	9.38	12.25	15.02	20.22
7.45	8.17	9.13	12.01	36	8.45	11.12	13.79	16.90	22.75
8.27	9.07	10.14	13.34	40	9.39	12.35	15.31	18.77	26.28
9.10	9.98	11.15	14.67	44	10.32	13.58	16.84	20.64	27.80
9.93	10.89	12.17	16.01	48	11.26	14.82	18.38	22.53	30.34
10.76	11.80	13.18	17.35	52	12.21	16.06	19.91	24.41	32.86
11.58	12.70	14.20	18.68	56	13.14	17.29	21.44	26.28	35.39
12.40	13.60	15.20	20.00	60	14.08	18.52	22.96	28.15	37.92
13.24	14.52	16.22	21.35	64	15.02	19.76	24.50	30.04	40.45
14.07	15.42	17.24	22.68	68	15.96	21.00	26.04	31.92	42.98
14.89	16.33	18.25	24.00	72	16.89	22.23	27.56	33.79	45.50
15.72	17.23	19.26	25.34	76	17.83	23.46	29.10	35.66	48.03
16.55	18.14	20.28	26.68	80	18.77	24.70	30.63	37.54	50.56

**Spiral Seams**

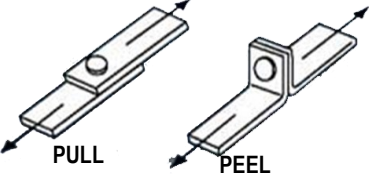
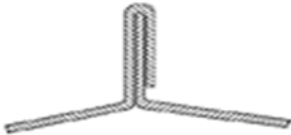
<p><b>SPIRAL</b></p>  <p><u>SPIRAL LOCK SEAM</u> SMACNA RL-1</p>	<p><b>SPS</b></p>   <p><u>OFFSET LAPPED, SPOT WELDED &amp; SEALED</u>     <u>LAPPED, SPOT WELDED &amp; SEALED</u> SMACNA RL-2     SMACNA RL-3</p>	
<p><b>SWB</b></p>  <p><u>SOLID BUTT WELD</u> SMACNA RL-4 20 GA, MIN</p>	<p><b>SWL</b></p>  <p><u>SOLID WELDED LAPPED</u> SMACNA RL-4 20 GA, MIN</p>	<p><b>ST</b></p>  <p><u>STITCH WELD</u></p>
<p><b>SC</b></p>  <p><u>SCREWED &amp; SEALED</u></p>	 <p><u>CLINCHED SEAM (NORLOCKED)</u></p>	 <p><u>STANDING SEAM</u></p>

DC Duct & Sheet Metal LLC • **301-864-3828** • [www.dcd duct.com](http://www.dcd duct.com)  
**202-575-0189**

*Your Local Spiral Duct & Oval Duct Connection*



**Singlewall Spiral Duct**

**SPR**

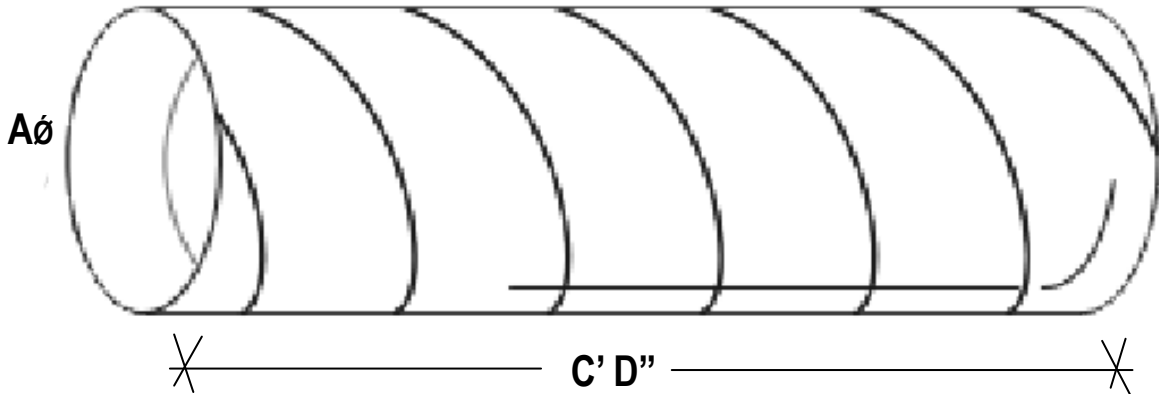

**SPR** \_\_\_\_\_ **STANDARD (SMOOTH)**

**SPR2** \_\_\_\_\_ **2-CORR**

**WE CORRUGATE ALL DUCT LARGER THAN 13 inches ...**

We will continue to do so unless we are instructed otherwise! We had the occasion when the corrugation was not wanted. This was when the spiral duct was going in a open ceiling and changed from corrugated to non-corrugated per our customer who made the request. There may be other reasons we are not aware of since we are not installers of any HVAC products.

DC Duct & Sheet Metal LLC • **301-864-3828** • [www.dcd duct.com](http://www.dcd duct.com)  
**202-575-0189**

*Your Local Spiral Duct & Oval Duct Connection*

# Fittings

SIZES 3" Ø THRU 12"

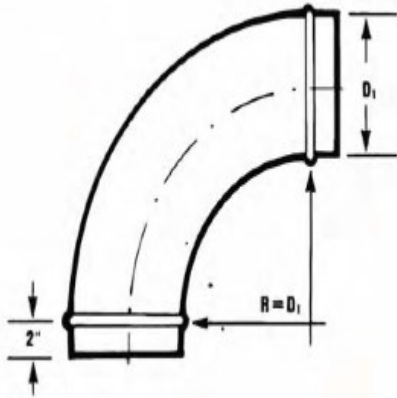

DC - 90  
 90° DIE STAMPED ELBOW  
 R = 1.5 X D  
 SPIRAL FITTINGS, INC

SIZES 3" Ø THRU 12"

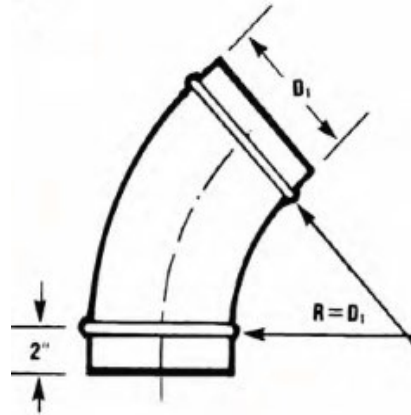

DC - 45  
 45° DIE STAMPED ELBOW  
 R = 1.5 X D  
 SPIRAL FITTINGS, INC

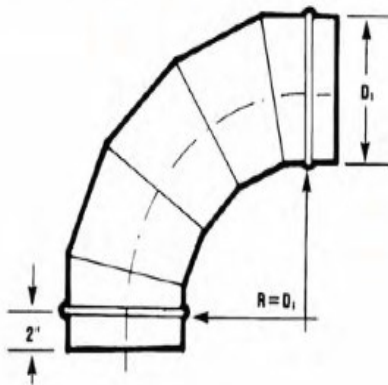

DC - 90  
 90° GORE LOCKED ELBOW  
 R = 1.5 X D

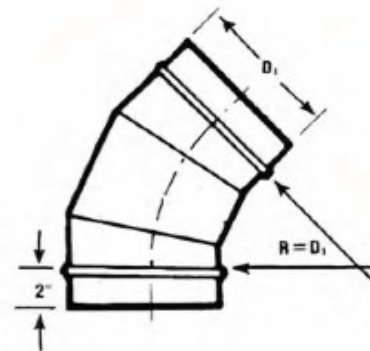

DC - 45  
 45° GORE LOCKED ELBOW  
 R = 1.5 X D

DC Duct & Sheet Metal LLC • **301-864-3828** • www.dcd duct.com  
**202-575-0189**

*Your Local Spiral Duct & Oval Duct Connection*

## Fittings

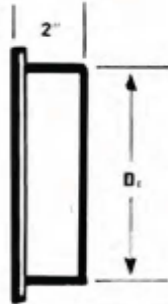

DC- P  
END CAP  
FOR PIPE

OR

DC- F  
END CAP  
FOR FITTING

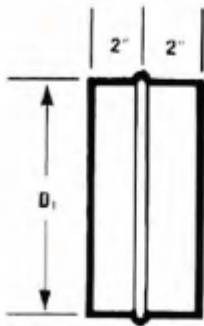

DC- P  
COUPLING FOR PIPE

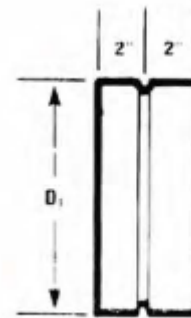

DC- F  
COUPLING FOR FITTINGS

DC Duct & Sheet Metal LLC • **301-864-3828** • [www.dcd duct.com](http://www.dcd duct.com)  
**202-575-0189**

*Your Local Spiral Duct & Oval Duct Connection*

# Fittings

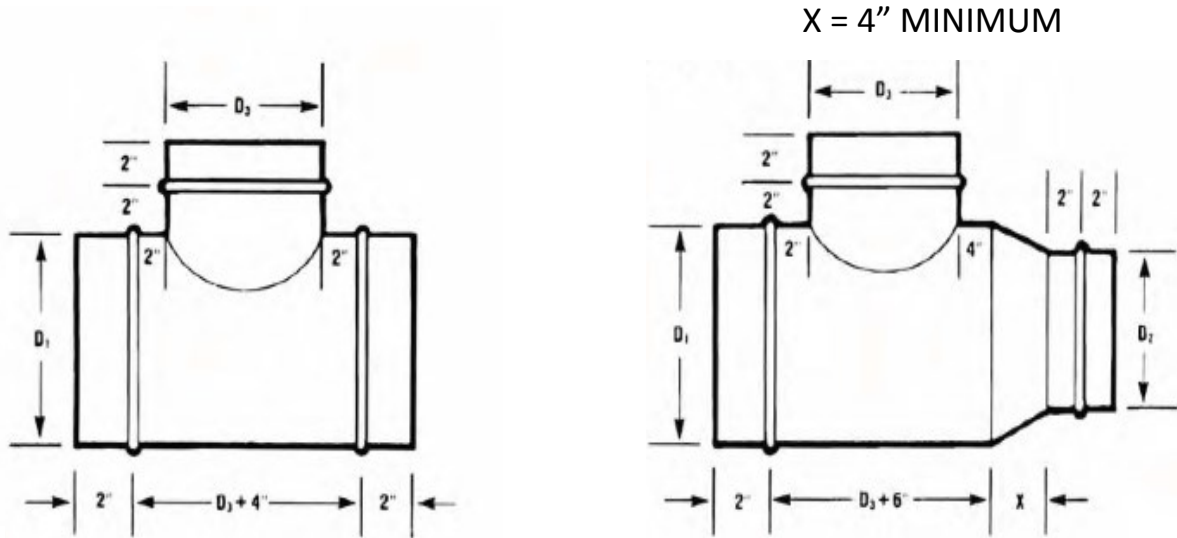

DCT - 90  
 90° TEE

DCT - 90 RT  
 90° REDUCER TEE

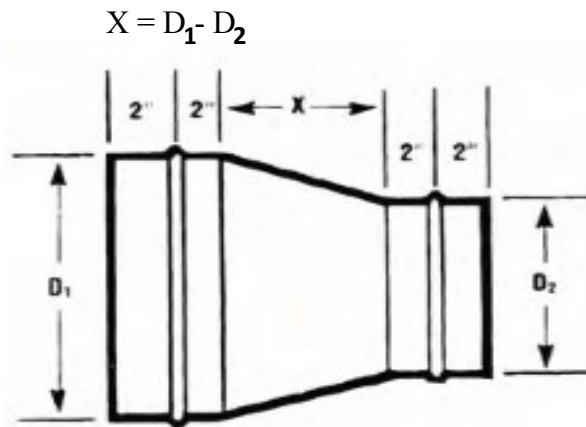

DC Duct & Sheet Metal LLC • **301-864-3828** • [www.dcd duct.com](http://www.dcd duct.com)  
**202-575-0189**

*Your Local Spiral Duct & Oval Duct Connection*

# Fittings

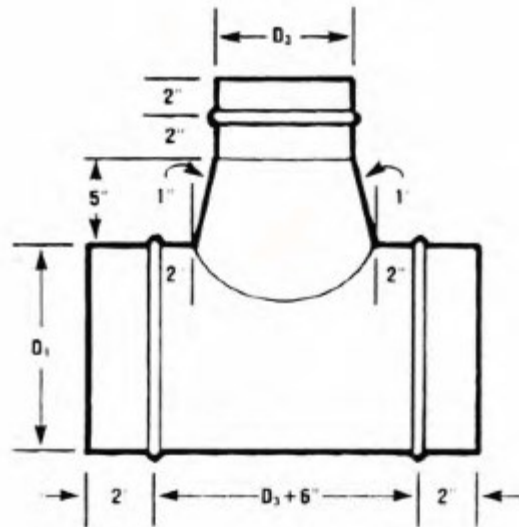

DCCT - 90  
 90° CONICAL TEE

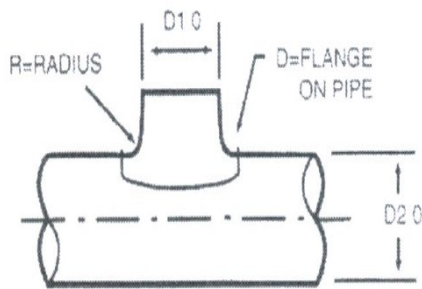

DC - TAP  
 45° OR 90° TAP

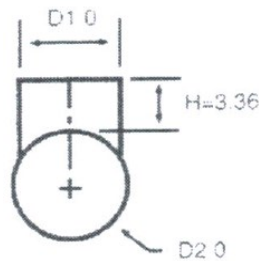

DCCT - TAP  
 90° SADDLE TAP

SHOP OR FIELD INSTALLED

DC Duct & Sheet Metal LLC • **301-864-3828** • [www.dcd duct.com](http://www.dcd duct.com)  
**202-575-0189**

*Your Local Spiral Duct & Oval Duct Connection*

**Fittings**

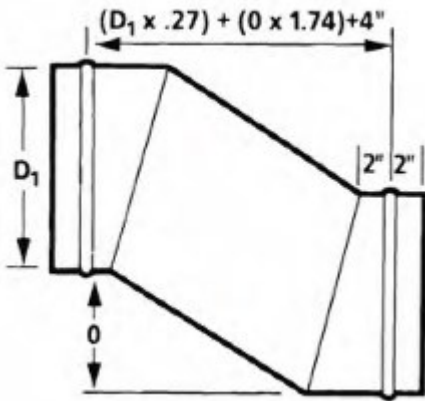

OFF  
 OFFSET

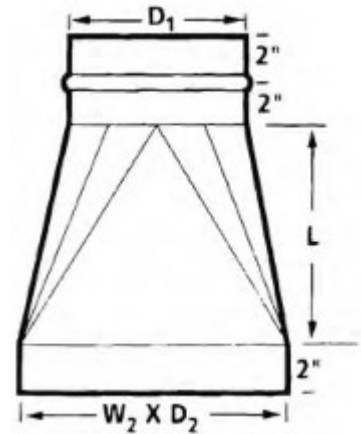

SQ 2RD  
 SQUARE TO ROUND

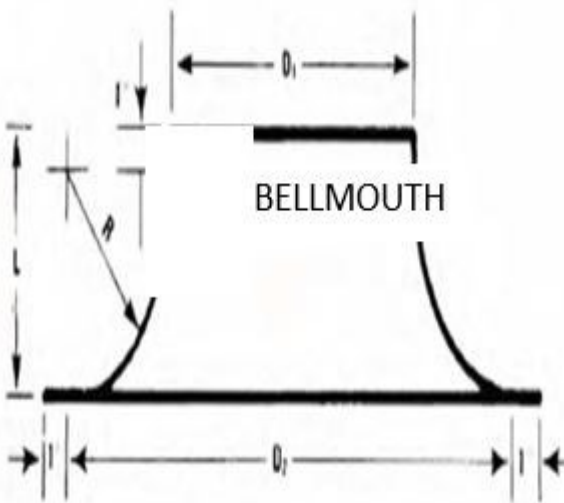

DC - BELLMO  
 BELLMOUTH



DC - BELLMOUTH  
 EXTENDED BELLMOUTH  
 With or Without Damper Available

DC Duct & Sheet Metal LLC • **301-864-3828** • [www.deduct.com](http://www.deduct.com)  
**202-575-0189**

*Your Local Spiral Duct & Oval Duct Connection*